



BOSCH
Invented for life

Unit injector for large engines

Precise fuel injection for maximum performance

Electronically controlled, therefore possible to adjust the injection quantity quickly and continuously

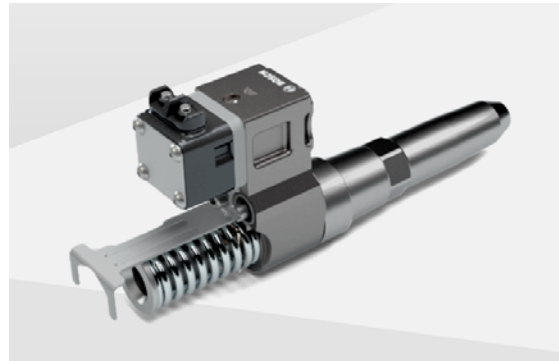

up to

1,800 bar

of injection pressure for efficient combustion

up to

20,000 h

of reliable operation due to robust system design

- ▶ The robust unit injector has an integrated high-pressure pump and injects the right amount of fuel required for efficient combustion into the cylinder.
- ▶ The advantage of the unit injector system is that there is no high-pressure line between the high-pressure pump and injection nozzle.
- ▶ The injection start and quantity are determined by the fast switching solenoid valve, although these variables can be freely selected in the program.
- ▶ For large engines > 2.5 l/cyl.